

Blata



MINIBIKE

2,5



EC Declaration Of Conformity

Manufacturer: Blata, s r.o.
Address: Prazska 9
678 01, Blansko
Czech Republic

Product: Minibike
Model: MINIBIKE BLATA
Derived types: MINIBIKE BLATA 2,5
MINIBIKE BLATA 2,6
MINIBIKE BLATA STYLE 60
MINIMOTARD BLATA 2,5
MINIMOTARD BLATA 2,6

The undersigned hereby declares, on behalf of BLATA s.r.o., that the above-referenced product, to which this declaration relates, is in conformity with the provisions of:

Council Directive 98/37/EC of 22 June 1998 on the approximation of the laws of the Member States relating to machinery and its amending directives

Council Directive 89/336/EEC of 3 May 1989 on the approximation of the laws of the Member States relating to Electromagnetic Compatibility (EMC) and its amending directives

and that the product has been designed to comply with the relevant sections of the below referenced specifications:

ČSN EN ISO 12100-1:2004 (EN ISO 12100-1:2003)
ČSN EN ISO 12100-2:2004 (EN ISO 12100-2:2003)
ČSN EN 294:1993 (EN 294:1992)
ČSN EN 811:1998 (EN 811:1996)
ČSN EN 953:1998 (EN 953:1997)
ČSN EN 563:1996 including amendment A1:2000 (EN 563:1994)
ČSN EN 1050:2001 (EN 1050:1996)
ČSN EN 55 012:2002
ČSN EN ISO 3744:1995
ČSN EN ISO 11202:1997

BLANSKO 1.5.2006

Pavel Blata
Managing Director

BLATA, s.r.o.
Pražská 9
678 01 Blansko
Czech Republic
IČO: 255 22 132
DIČ: CZ25522132



SAFETY WARNING

Always pay attention to the instructions and safety warnings below

This manual contains important safety information and instructions which should be read carefully before operating the vehicle. For your own safety and the safety of others follow these rules.

Neither manufacturer nor distributor is responsible for injuries caused by unsafe and improper use of the vehicle.



This vehicle is not allowed to be used on public roads!



Unsafe and careless use of the vehicle can result in serious injuries. The driver can minimize the potential risks by wearing safety equipment. The driver must wear a safety helmet, goggles, gloves, elbow pads, kneepads, and firm footwear. Avoid rough surfaces and obstacles. Always drive with both hands on the handlebars.



Always inspect the bike before each ride (refer to the article 'INSPECTION AND MAINTENANCE'). Failure to inspect and maintain your Quadard properly increases the risk of an accident or damage to the vehicle.



Fuel and fuel vapour are highly toxic and flammable. Always be careful when handling fuel – it can burn or poison you.

- stop the engine and turn off the fuel tap, keep naked flames and sparks away from your bike.
- do not smoke near your bike.
- refuel only outdoors in a well ventilated space
- clean up any excess fuel immediately
- keep children and pets away



Always ride within the limits of vehicle/ rider and weather conditions to avoid unnecessary accidents and injuries.



Check-ups
Shut the engine off when performing maintenance check-ups otherwise You could be severely injured if your hands or clothing get caught by moving parts.



Make sure the engine and exhaust are cold before performing any inspection of this machine



Riding with a chain in poor condition or improperly adjusted can lead to serious injury. Always, Inspect, Adjust and Maintain the drive chain properly before each ride.



Failure to inspect and properly maintain the brake increases the risk of having an accident. Before each ride check the rear brake cable and the brake efficiency.



Riding with worn brake pads can reduce the braking performance and cause an accident. Check and replace brake pads according to the instructions in this manual.



Using worn, improperly inflated, or incorrect tyres will reduce stability and can cause an accident.

DISPOSAL OF UNUSABLE PRODUCT

Unusable product become a waste and it's desposal should be in accordance with the law and any applicable local regulations. Don't throw this product to municipal waste.

MINIBIKE 2,5

SERVICE MANUAL FOR USE AND MAINTENANCE OF MINIBIKE

Before starting the operation of your Minibike, read thoroughly these directions.

CONTENTS

	PAGE
INTRODUCTION	2
BASIC TECHNICAL DATA	2
UNPACKING AND BASIC CONTROLS - FIG. 1	3
SAFETY	3
BEFORE STARTING	3
STARTING THE ENGINE - FIG. 2	4
CARBURETOR - FIG. 3	4
RIDE	5
PERIODIC MAINTENANCE	5
CHAIN SETTING	5
CLUTCH PADS REPLACEMENT	5
ENGINE - EXPOSIVE VIEW	6
MINIBIKE - EXPLOSIVE VIEW - FIG. 5	7
PARTS LIST	8,9
FRONT AND REAR BRAKES - FIG. 7	10
ADJUSTING THE BRAKES - FIG. 4	11
FRONT BRAKES PADS REPLACEMENT - FIG. 7	11
REAR BRAKES PADS REPLACEMENT - FIG. 7	11
DISMANTELING AND MOUNTING THE FRONT WHEEL - FIG. 5	11
DISMANTELING AND MOUNTING THE REAR WHEEL - FIG. 5	12
PINION EXCHANGE - FIG. 6	12
DISMANTELING AND ASSEMBLY OF AIR FILTER - FIG. 3	12
NON USE AND STORAGE PROCEDURE	13

INTRODUCTION

Minibike 2,5 is intended for a drive on closed tracks with even, smooth, and dust-free surface. Both grown - up and children can ride on the Minibike. Children only under the supervision of a grown - up and responsible person. If the terms of a track are fulfilled, the Minibikes can be used for races. Minibike Blata should not be used during winter season and under bad weather conditions. Usage under these conditions leads to abnormal mechanical wear and corrosion of most minibike parts - especially those directly exposed to climatic influences. Beside that, riding under these conditions increase the risk of injury or health damage.

Minibike is equipped with a single - cylinder, two - stroke, petrol combustion engine, with a front and rear disc brake, the rear one being controlled by a lever on the left side of handlebars and the front one by a lever on the right side of handlebars, when seeing in the ride direction. The fuel quantity controlled by a handle on the right side of handlebars. The engine is fitted with an air filter and a exhaust silencer. The driving moment transmission from engine to the driven rear wheel is carried out by a chain drive the ratio of which can be changed to a small extent by a sprocket wheel exchange on the rear wheel.

BASIC TECHNICAL DATA

ENGINE:	TWO - STROKE	AIR COOLED
	CILINDER CAPACITY	39,9 ccm
	POWER OUTPUT	2,5 kW at 8 700 rpm
	TORGUE	3,5 Nm at 6 000 rpm
	CARBURETOR	DELL'ORTO
	IGNITION	ELECTRONIC
	STARTING	MANUAL
	CLUTCH	CENTRIFUGAL, FRICTION
FRAME:	WELDED	OF HIGH - STRENGTH STEEL TUBES
LINING:	THREE PARTED
BRAKES:	FRONT WHEEL	MECHANICAL DISC BRAKES
	REAR WHEEL	MECHANICAL DISC BRAKES
WHEELS:	FRONT WHEEL	OF LIGHT ALLOY 4" - 51
	REAR WHEEL	OF LIGHT ALLOY 4" - 95
TIRES:	FRONT	3,00 - 4" WITH PATTERN
	REAR	3,00 - 4" WITH PATTERN
TUBES:	FRONT + REAR	3,00 - 4"
FUEL:	MIXTURE OF PETROL 91 OR HIGHER OCTANE + 2-STROKE SYNTHETIC OIL
	MIXING RATIO	50 : 1
	TANK CAPACITY	1 LITRE
HIGHEST VELOCITY IN ACCORDANCE WITH THE INSTALED RATIO:		
		up to 28 mph (45 km/ h)
	UNLOADED WEIGHT	37,5 lb (17 kg)
	CARRYING CAPACITY	242 lb (110 kg)
BASIC DIMENSIONS:		
	LENGHT	36,2" (920 mm)
	WIDTH	20" (500 mm)
	HEIGHT	20 " (500 mm)

UNPACKING AND BASIC CONTROLS:

The Minibike is packed and delivered with folded handlebars and levers mounted on them. After unpacking, set up the handlebars in such a function position that will suit you best. However at maximum handlebars turning, the brake levers must not bump into the lining. After setting - up the handlebars, tighten the nuts 1 on handlebars sleeves, the brake levers 2, and acceleration handle 3 acc. to Fig. 1. At tightening, don't use an excessive force in order not to damage the parts or threads, or to distort the tubes, and the like. Verify the smooth and perfect movement of operating bowden cables of acceleration and both brakes.

Fig. 1

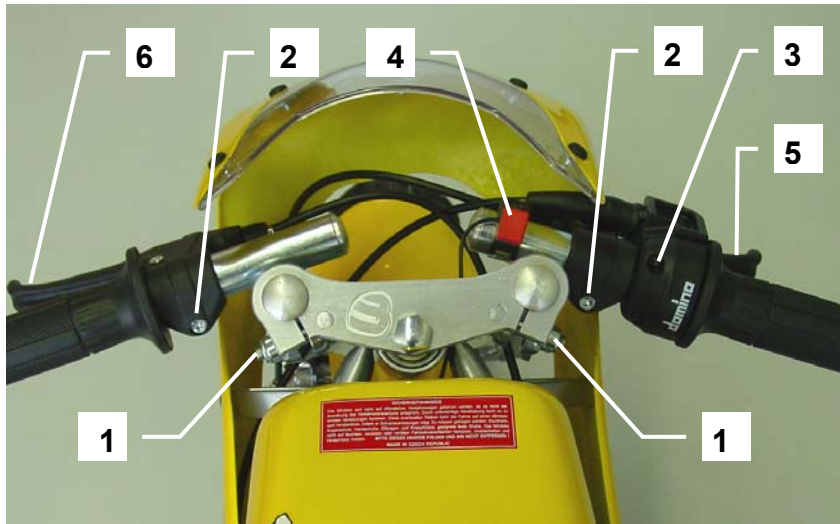

Basic controls:

1. Handlebars nut
2. Brake lever bolts
3. Acceleration handle screws
4. Stop switch
5. Front brake lever
6. Rear brake lever

SAFETY

Minibike is not allowed to be used on public roads, as it doesn't comply with valid Safety Standards. It is forbidden to ride even where the traffic of larger vehicles is possible. Minibike is intended for a drive on closed tracks with even smooth and dust-free surface. For your own and other people's safety keep all advices and recommendations, how to use your minibike in a correct and thoughtful way. serious injuries can result from unsafe operation of this and other vehicles. You have to minimize the risk by wearing Safety Equipment e. g. : safety helmet, goggles, gloves, guards of elbow and knees, firm footwear.

BEFORE STARTING

Regarding the engine life time it is important the minibike to be well run - in as this fact will manifest itself by the power output and life of engine. The minibike is considered to be run - in after consuming five full fuel tanks by riding. For brake-in period we use mixture of petrol and 2-stroke synthetic oil in the ratio 30 : 1. After brake-in the petrol octane no. 91 or higher and 2-stroke synthetic oil are mixed in ratio 50 : 1. Mix up thoroughly the mixture of fuel and oil before pouring it into the tank. During brake-in don't increase the engine speed to maximum and don't allow the overheating. Check the tire inflation which should correspond to the driver's weight. The pressure in one wheel has not to exceed 2,5 bar in the front and rear wheel.

STARTING THE ENGINE

To be done only on the starting stand - Fig. 2. After opening the tank filling hole, fill the tank with fuel and close it by screwing - in cap. Open the petrol supply cock by turning the small lever into position "ON", Fig.3. Set the choke lever into position "C" , Fig. 3. Without turning the accelerating handle, pull gently twice the starting wire and by next quick pull start the engine. It is not allowed to pull the starting wire up to full winding off. After a short engine run, put the choke lever back to position "A" and let the engine run about 1 min. Let the Minibike on the larking stand and, if need be, adjust the no - load speed to such a rate lest coupling should take along the no - load speed to such a rate lest coupling should take along the rear wheel. For adjustment use the adjustment screw No. 4 on the carburetor, Fig. 3.

Fig. 2



Fig. 3

CARBURETOR

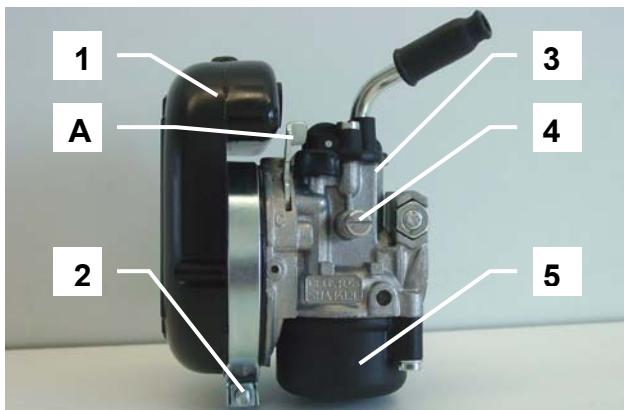

1. Suction chamber
 2. Sleeve screw
 3. Carburetor body
 4. Adjusting screw of no - load run
 5. Float chamber
 6. Fuel cock
- A – choke lever for ride
B – choke lever for cold - starting

It is necessary to adhere to the following instructions for flange reassembling: always use a new plastic ring 110.078.00 which is inserted into the flange! Tighten up the screw with torque 5 Nm. Use of bigger torque can cause carburetor damage which is not covered by warranty !! Use of smaller torque can cause slacking of the carburetor.

Check up the screw tightness after every 5 hours of riding!

RIDE

After mounting the Minibike and slow turning the acceleration handle, you are starting your ride. Before braking, turn back the acceleration handle and depress slightly the front brake lever and then the rear brake lever. Beware of the wheels not to get them in skid.

The Minibike engine will be switched off by pushing the red push - button of the stop switch on handlebars. After the first half- hour ride it is necessary to check the tightening of screws and nuts, especially of the engine. Check also the brake setting.

PERIODIC MAINTENANCE

The periodic maintenance is the best way how to contribute to the machine life prolongation, ride safety, and cost decrease. In addition, you will be spared many worries, time and troubles.

A - Before every ride:

1. Check the Cables and efficiency of brakes.
2. Check the lubrication and chain tension settings. The chain free play should be (5 mm) (.200in) After every ride clean the minibike carefully and keep it clean. Do not use aggressive cleaning detergents.
3. After 1-hour of use, wash the air filter in air drying spirits and lubricate it with special oil for air filters.

B. After every 5 hours of riding:

4. Check the tightness of all bolts and nuts. Tighten carefully to prevent damage to other parts.
5. Wash the air filter in gas and lubricate it with special oil for an air filters to better catch the dust.
6. Clean carefully the carburetor float chamber.
7. Check the brake pads, the thickness of brake lining cannot be less than 1 mm (.039 in). Review the basic brake adjustment.
8. Check the state of the clutch pads - the thickness cannot be less than 1 mm (.039in).

C - Every time after 10 hours of riding:

9. Check the state of the clutch pads - the thickness cannot be less than 1 mm (.039in).

CHAIN SETTING:

When setting up the chain attachment of the rear brake reaction catcher and the rear wheel axle nut 920.011.01. Then tighten uniformly the chain tighteners on both sides of rear wheel by means of nuts 920.009.01 , Fig. 5. When the chain is set - up to required sag 0,196" (5 mm), tighten the nut 920.011.01 of the rear wheel. If there is need to replace the chain, check also both chain wheels. In case they are worn-out, they must be replaced by new ones at the same time with the chain.

REPLACEMENT OF THE CENTRIFUGAL FRICTION CLUTCH PADS:

After unscrewing two side screws remove the front lining. Unscrew the fastening screws and remove the chain cover. Release the chain and dismantle it. Unscrew four screws keeping the cover with drum of the clutch. Release the engine brace on the frame, shift it out, and remove the whole cover with clutch drum. By means of pliers draw off the clutch springs and loosen the pins holding the clutch levers. At the new clutch levers put the clutch pins and at assembly proceed in a reverse sequence and, in the end, adjust the chain sag.

MINIBIKE - 2,5

110.000.00	MINIBIKE 2,5	510.002.00	STARTER COMPLETE
	<u>ENGINE</u>	510.003.00	STARTER ROPE
110.001.00	ENGINE COMPLETE	510.004.00	HOLDER
110.001.01	ENGINE PROPER	510.005.00	HOLDER
110.002.00	CARBURETTER SHA 1412L	510.006.00	GUIDE BUSH
110.004.00	PISTON COMPLETE - A	510.007.00	STARTER CASE
110.004.01	PISTON COMPLETE - B	510.008.00	STARTER SPRING
110.004.02	PISTON COMPLETE - C	510.009.00	RATCHET WHEEL
110.004.03	PISTON COMPLETE - D	510.011.00	WASHER 4,5 x 16 x 1,5
110.005.00	PISTON RING	510.015.00	WASHER 8,1 x 16 x 1
110.006.00	PISTON - A	510.017.00	WASHER 6,1 x 16 x 1,5
110.006.01	PISTON - B	510.020.00	PINION
110.006.02	PISTON - C		
110.006.03	PISTON - D		<u>FRAME</u>
110.008.00	WRIST - PIN	111.001.01	FRAME, VARNISHED
110.011.00	CRANK BALANCED		
110.015.00	CLUTCH DISC		<u>BRAKES</u>
110.017.00	CLUTCH LEVER - 2 PCS	112.004.00	LIFTER, RIGHT
110.019.00	CLUTCH SCREW COMPLETE	112.050.02	BRAKE HOLDER
110.020.00	CLUTCH SCREW SCREW	112.060.00	BRAKE COMPLETE
110.021.00	CLUTCH SPRING - SERIE 1,25 - 2PCS	132.001.01	FRONT BRAKE DISC 2,5 x 119
110.022.00	CLUTCH SPRING - RACING 1,4 - 2PCS	202.006.00	BOWDEN CABLE - FRONT BRAKE
110.023.00	CLUTCH SPRING - RACING 1,6 - 2PCS	202.007.00	BOWDEN CABLE - REAR BRAKE
110.024.00	CLUTCH DRUM	312.017.00	LIFTER LEVER
110.028.00	CLUTCH CASE	312.029.00	SPRING, LEFT
110.031.00	CLUTCH CASE COMPLETE	312.035.00	WASHER 6,1 x 14 x 3
110.032.00	CLUTCH COMPLETE	312.040.02	REAR BRAKE DISC 3,0 x 119
110.053.00	ENGINE COVERING	312.041.00	WASHER 10,5 x 18 x 3
110.055.00	ENGINE SEALING SET	332.020.00	NUT
110.056.00	FLANGE	512.004.00	HANDLE BAR LEVER, RIGHT
110.057.00	DIAPHRAGM SEALING - 2PCS	512.005.00	HANDLE BAR LEVER, LEFT
110.059.00	DIAPHRAGM	512.008.10	LIFTER, LEFT
110.060.00	DIAPHRAGM WASHER	512.016.50	TERM. CLAMP BOWDEN
110.063.00	SEALING ENGINE BLOCK	512.019.01	WASHER
110.065.00	ENGINE BLOCK	512.042.00	DISTANCE SLEEVE
110.067.00	DIAPHRAGM COMPLETE	512.043.00	BRAKE PIN
110.068.00	SEALING	512.044.00	LIFTER PIN
110.069.00	CYLINDER - A	512.045.00	BOWDEN HOLDER
110.069.01	CYLINDER - B	512.053.00	FRONT BRAKE CASE - 1 PAIR
110.069.02	CYLINDER - C	512.054.00	DISC BRAKE PADS - 1 PAIR
110.069.03	CYLINDER - D	512.055.00	BRAKE COMPLETE
110.070.00	CYLINDER + PISTON COMPLETE	512.058.00	REAR BRAKE CASE - 1 PAIR
110.072.00	EXHAUST SEALING	512.060.00	SPRING RIGHT
110.073.00	PLASTIC CONECT, FUEL COCK		
110.074.00	FUEL COCK		
110.075.00	EXHAUST COMPLETE		<u>WHEELS</u>
110.076.00	EXHAUST SILENCER COMPLETE	113.001.00	DISC 4" - 51
110.077.00	SILENCER MASS	113.002.01	WHEEL COMP. 4" - 95 WITHOUT TIRE
110.078.00	RING	113.005.00	TIRE WITH PATTERN 3,00 - 4"
110.080.52	JET 52	113.007.00	TUBE 3,00 - 4"
110.097.00	FLOAT CHAMBER SEALING	113.008.00	AXLE OF WHEEL
110.098.00	CARBURETOR SEALING 1	113.009.00	AXLE OF WHEEL
110.099.00	ADJUSTING SCREW		
110.100.00	THROTTLE VALVE	113.015.00	DISTANCE SLEEVE, 14,5 mm
110.101.00	CARBURETOR FILTER	113.016.00	CHAIN ADJUSTER, COMPLETE
110.102.00	NEEDLE VALVE	113.019.00	WHEEL COMP. 4" - 51 WITHOUT TIRE
110.103.00	FLOAT	113.020.00	DISC 4" - 95
110.104.00	CARBURETOR SEALING 2	513.011.03	DISTANCE SLEEVE 139,3mm
110.105.00	THROTTLE VALVE SEALING	513.011.04	DISTANCE SLEEVE 84,5 mm
110.185.00	JET SET	513.011.07	DISTANCE SLEEVE 85,3mm

LINING
114.001.01 LINING COMPLETE, NON VARNISHED
114.002.30 LINING COMPLETE, VARNISHED
114.003.01 FRONT LINING, NON VARNISHED
114.004.00 SADDLE, NON VARNISHED
114.005.00 FRONT FENDER, NON VARNISHED
114.006.30 FRONT LINING, VARNISHED
114.007.00 SADDLE VARNISHED
114.008.00 FRONT FENDER, VARNISHED
114.015.00 CHAIN COVER
114.016.00 CHAIN COVER, POLISHED
334.009.00 WINDSHIELD + RIVET
514.008.00 RUBBER WASHER 5 x 5,5 x 23,5

CONTROL
115.001.05 FORK LEFT WITH BRAKE HOLDER
115.002.00 FORK RIGHT
115.005.00 HANDLE BAR TUBE
115.011.00 THROTTLE GAS
115.014.00 BOWDEN DUST GUARD
115.015.00 HAND GRIPS - 2 PCS
115.016.00 GAS BOWDEN CABLE
345.100.00 CAP
115.021.01 HOLDER ABOVE - COMPLETE
115.022.01 HOLDER BELOW - COMPLETE

TRANSMISSION
117.010.54 SPROCKET NO. TEETH 54
117.010.55 SPROCKET NO. TEETH 55
117.010.56 SPROCKET NO. TEETH 56
117.010.57 SPROCKET NO. TEETH 57
117.010.58 SPROCKET NO. TEETH 58
117.010.59 SPROCKET NO. TEETH 59
117.010.60 SPROCKET NO. TEETH 60 - SERIE
117.010.61 SPROCKET NO. TEETH 61
117.010.62 SPROCKET NO. TEETH 62
117.010.63 SPROCKET NO. TEETH 63
117.010.64 SPROCKET NO. TEETH 64
117.010.65 SPROCKET NO. TEETH 65
117.015.00 CHAIN CLASP
117.015.01 CHAIN CLASP
517.001.28 CHAIN 128
517.001.30 CHAIN 130
517.001.32 CHAIN 132 - SERIE
517.001.34 CHAIN 134

EL. INSTALLATION
118.001.00 SPARK COIL
118.002.00 ROTOR COMPLETE
118.003.00 SPARK PLUG
118.005.00 SPARK PLUG CONNECTOR
118.010.00 ZIP TIES 3,6 x 140
518.001.00 KILL SWITCH

OTHER PARTS
119.002.00 LABEL COMPLETE, ONE MODEL
119.003.00 DISTANCE SLEEVE 25,8
119.004.00 SADDLE RUBBER - COMPLETE
119.005.00 CHAIN ROLLER
119.006.00 HOLDER ENGINE
119.008.00 TANK WITH CAP

119.009.00 TANK
119.010.00 SCREW CAP
119.011.00 RUBBER FOR FRAME
119.012.00 GAS TUBE
119.013.00 HOSE CLAMP
119.020.00 STAND
119.035.00 WASHER 6,4 x 18 x 1
129.008.00 HOSE CLAMP
329.001.01 FOOT REST, 2 PCS

JOINING ELEMENTS
911.007.01 SCREW M 10 x 140
912.003.01 SCREW M 5 x 25
912.006.02 SCREW M 5 x 16
912.007.01 SCREW M 5 x 16
913.003.01 SCREW M 8 x 35
914.001.01 SCREW M 5 x 16
914.003.01 SCREW M 5 x 20
914.005.01 SCREW M 5 x 30
914.007.01 SCREW M 6 x 16
914.008.01 SCREW M 6 x 20
914.009.01 SCREW M 6 x 22
914.010.01 SCREW M 6 x 25
914.011.01 SCREW M 6 x 30
914.080.01 SCREW M 6 x 14
915.001.01 SCREW M 4 x 8
915.004.01 SCREW M 4 x 10
916.005.01 SCREW M 6 x 16
916.020.01 SCREW M 6 x 40
916.065.02 SCREW M 5 x 25
916.072.02 SCREW M 5 x 20
920.001.01 NUT M 5
920.006.01 NUT M 6
920.008.01 NUT M 5 SELFLOCKING
920.009.01 NUT M 6 SELFLOCKING
920.010.01 NUT M 8 SELFLOCKING
920.011.01 NUT M 10 SELFLOCKING
920.012.01 NUT M 8 LEFT

930.003.01 WASHER 10,5
930.009.00 WASHER 6,4
930.010.00 WASHER 8,4
930.011.00 WASHER 8,1
940.001.00 RIVET 4 x 8
940.006.00 ROLLER 6 x 6
940.008.00 RIVET BULBEX 4,2 x 18,8 WITH CAP
950.003.00 WOODRUFF KEY 3e7 x 3,7
950.005.00 WOODRUFF KEY 2e7 x 3,7
950.007.00 LOCK 15
950.008.00 LOCK 35
950.010.00 PISTON PIN LOCK RING

960.003.00 BEARING 6000 ZR
960.004.00 BEARING 6200 ZR
960.006.00 BEARING 6202 C3
960.007.00 BEARING 6202 ZZR
960.108.00 CONNECTING ROD BEARING
970.001.00 PACKUNG RING 12 x 22 x 7
970.002.00 PACKUNG RING 15 x 26 x 7

FRONT BRAKE - COMPLETE

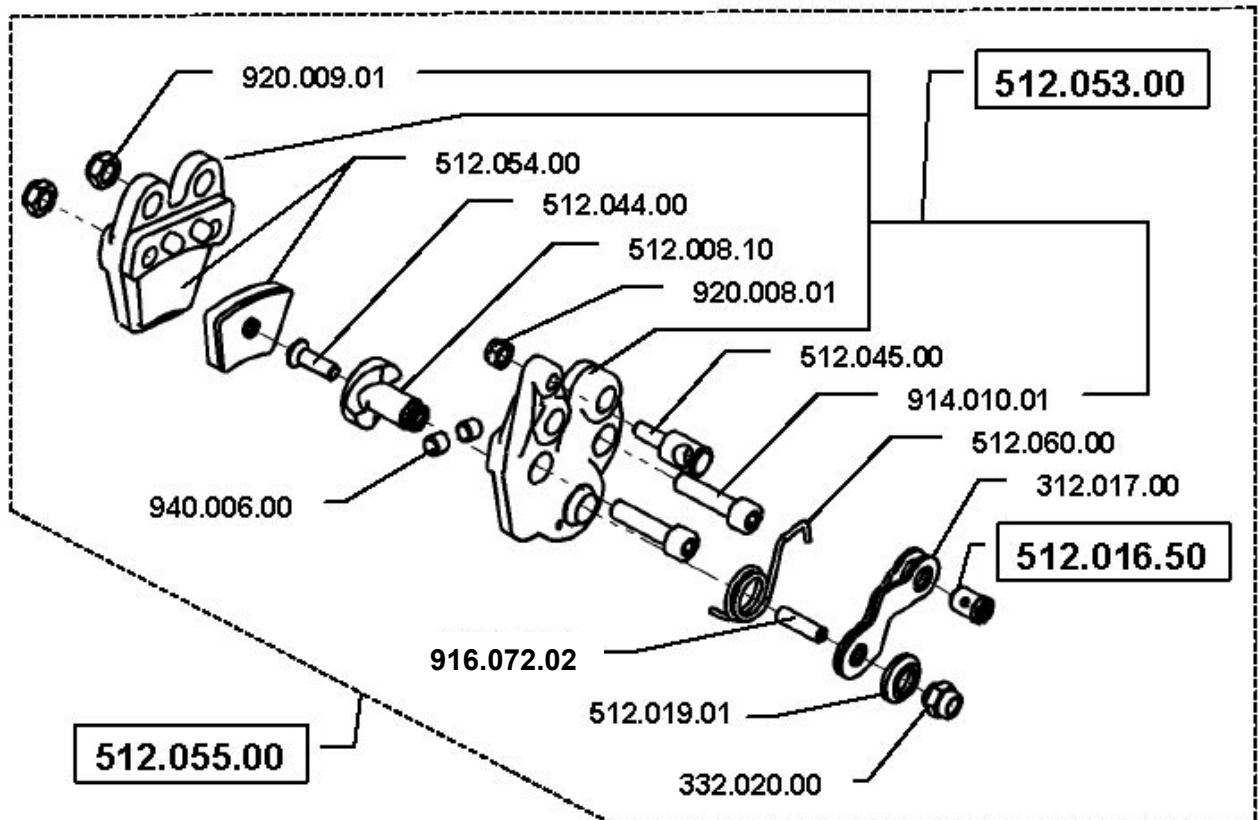

REAR BRAKE - COMPLETE

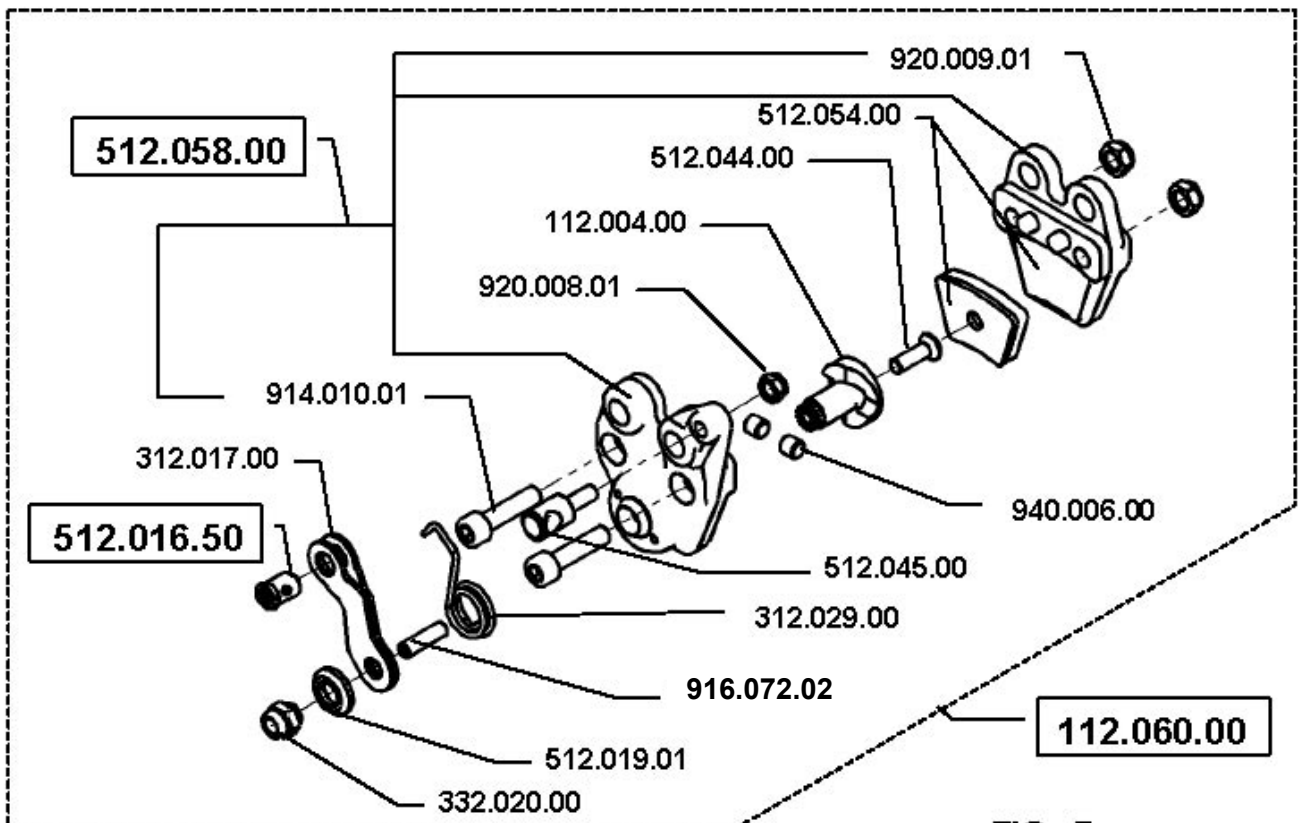
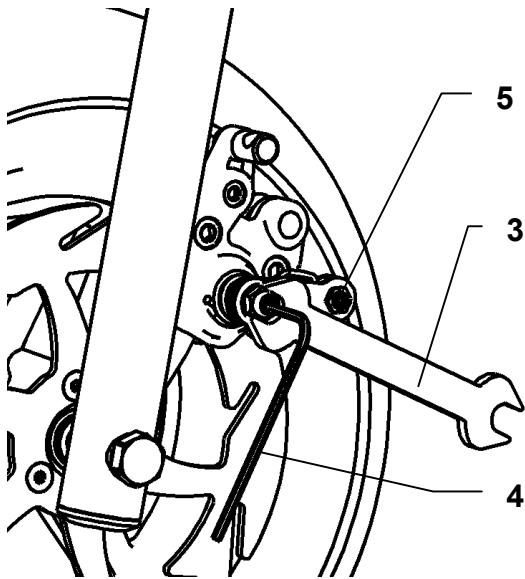

FIG. 7

ADJUSTING THE BRAKES



Small incremental brake adjustment :

Free play at the handlebar lever is effected by turning the knurled end on the cable adjustor. This will allow the lever to be set at the nominal to $\frac{1}{4}$ inch of free lever movement.

Basic brake adjusting:

Screw in the knurled cable adjustor at the brake lever so the cable is in it's most slack starting position.. At the caliper, loosen the nut, No. 3 and tighten the adjustable bolt No. 4, so the wheel cannot turn. Back off bolt No. 4 about $\frac{1}{4}$ to $\frac{1}{2}$ of a turn and fix it with lock nut No. 3. **Do not use the cable retainer No. 5 for adjusting the brakes!**

FRONT BRAKE PADS REPLACEMENT: FIG.7

At first, screw in the knurled cable adjustor at the brake lever on the handlebars. Unscrew two screws M5-914.003.01 that hold the brake body on fork and shift out the brake backwards. Take out from brake body two distance columns and two columns with coil. **Do not loosen the cable retainer!** Unscrew screws M6-914.010.01 and separate both halves of brake body and shift the worn-out brake plates out. Into the part with operating mechanism slide the brake plate with pin bore and unscrew completely the adjusting screw. Force on carefully the brake plate into the opposite piece. Before reassembly clean the whole brake. Assembly follows in reverse sequence.

REAR BRAKE PADS REPLACEMENT: FIG. 7

At first, screw in the knurled cable adjustor at the brake lever on the handlebars. Unscrew two screws M5-914.003.001 that hold the brake body on brake holder and shift out the rear brake backwards. Take out from brake body two distance columns and two columns with coil. **Do not loosen the cable retainer !** Unscrew screws M6-914.010.01 and separate both halves of brake body and shift the worn-out brake plates out. Into the part with operating mechanism slide the brake plate with pin bore and unscrew completely the adjusting screw . Force on carefully the brake plate into the opposite piece. Before reassembly clean the whole brake. Assembly follows in reverse sequence.

DISMANTLING AND MOUNTING THE FRONT WHEEL, FIG. 5

Unscrew the front axle nut 920.011.01 and shift out the axle. By light pull shift downwards the wheel. Take care, at releasing the wheel the distance roller and shim fall out. At mounting the wheel, direct first carefully the front brake and wheel with brake disk so that the brake disc slides in the space between the brake plates. Insert the distance roller 513.005.01 between the brake disc and fork, then insert partly the wheel axle. Insert the distance shim 930.003.01 between the wheel and right fork and slide in the wheel axle. Screw-on and tighten the nut 920.011.01 of wheel axle.

DISMANTLING AND MOUNTING THE REAR WHEEL, FIG. 5

Unscrew the rear axle nut 920.011.01 and loosen the nuts 920.009.01 on chain tighteners. Shift the wheel forward and remove the chain. At pulling out the wheel axle, secure the rear wheel two distance rollers fall out.

The wheel mounting to be carried out in reverse sequence. It is necessary to see to the right location of distance rollers. Use the shorter roller on the site of chain wheel and the longer one at the brake disc. Don't forget to tighten right the chain, tighten the wheel axle and check the rear brake function.

PINION EXCHANGE: FIG. 6

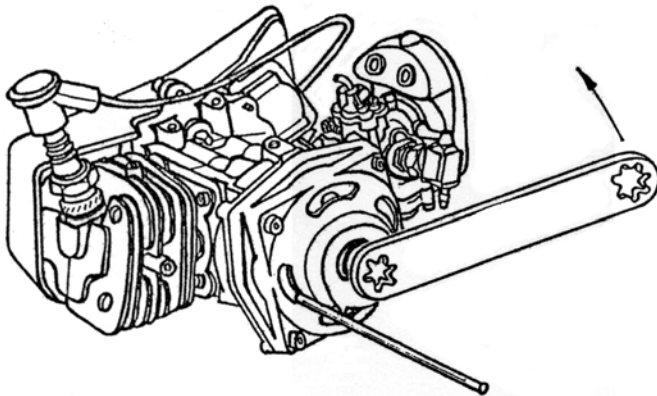

FIG.6

First dismantle the front lining and chain guard. Loosen the nut of rear wheel axle and the nut of chain tightener, remove chain. Insert carefully a larger screwdriver or steel rod into the hole of clutch drum, Fig. 6, to avoid a turning over the clutch drum at releasing the pinion. Using the pinion wrench P/ N 319.050.00, release the new pinion to be carried out by reverse way.

TIRE EXCHANGE, FIG. 5:

First, dismantle the wheel from the Minibike. At the front wheel unscrew the screws 912.003.01, remove the brake disc 112.025.00 and the distance shims 112.029.00. Unscrew the tire valve and deflate the tire. Then, unscrew the screws 914.011.01, thus releasing both disc halves 513.001.00 each other. Only then you can exchange the tire or inner tube. At the rear wheel unscrew the screw 914.001.01 from both sides, remove the brake disc and sprocket wheel and then proceed in the same way as with the front wheel. The reassembly to be carried out by following way. Put the inner tube in the new tire so that the tire valve points to the right at the front wheel and to the left at the rear wheel in travel direction. Insert a half-disc of tire from the tire valve side and put in the wheel axle. Put in the distance tube from inner side. Mount the other half - disc into the tire and tighten the bolts 914.011.01 and nuts 920.009.01. Pump-up the tire maximum to 2,5 bar. and mount the wheel by a reverse way.

DISMANTLING AND ASSEMBLY OF AIR FILTER, FIG. 3

Dismantling the air filter unscrew 2 and so ease the holder and put down the suction chamber 1. On this way you gain access to the filter, that you can take off by means of screw driver. After cleaning and lubricating it with engine oil proceed the assembly on a reverse sequence.

NON USE AND STORAGE PROCEDURE

It is recommended to drain out all fuel from the tank and carburetor. Inflate the tires to the working pressure and put the minimotard on the stand. During a long storage period*, unbolt the spark plug and insert a couple of drops of the motor oil into the cylinder. Pull the starting rope a couple of times so a film of oil covers and evenly coats the cylinder walls and piston rings.

* Long period is 90 days and longer.

Rights reserved for technical, text and design changes of the BLATA Company.

It is a great honor for us, that you have chosen our product. We believe that the MINIBIKE will work for you without problems and will bring you much pleasure and fun.

The producer of the MINIBIKE is BLATA Company.

Manufacturing Number : CZ.....

Signature of the technical control:

This manual served also as a GUARANTEE LIST. Please, after receiving the product check the manufacturing number and the date of sale. In the case of a claim it is necessary to submit this guarantee list.

Rights of a purchaser governed by special legislation relating to the purchase of goods are not violated by granting the warranty.

Date, stamp and signature of the dealer:

The entire construction solution for minibike and used disc brakes are protected by industrial design.

No part of this publication may be reproduced without an explicit consent of BLATA COMPANY!